

CORA[®] CRUSHER

For separation of lumped powder



The sanitary CORA CRUSHER is used for separation of lumped powders and oversized materials. Typical applications include breaking up lumps as they are being discharged from a vacuum dryer as well as pre-breaking prior to a sieve or mill.

FEATURES:

- Modular, compact construction used as a pre-breaker in conjunction with a sieve, mill, etc.
- Throughput range: 1,650 lbs./hour up to 6,500 lbs./hour
- Specifically designed for stringent FDA & USDA sanitary requirements
- Suitable for CIP and SIP
- Easy to detach, disassemble and thoroughly clean
- Improves product flow

CONSTRUCTION/FINISH:

- AISI 316L Stainless Steel
- #7 mirror finish (Ra=20u-in) on product contact surfaces
- #4 finish on external surfaces (Ra=50u-in)
- cGMP compliant with FDA CRF 21, 177.2600

OPTIONS:

- Electronic motor driven using a slide bracket and flexible coupling for quick disassembly
- Motor encased in stainless steel enclosure

AVAILABLE SIZES:

- 4" (100mm), 6" (150mm), 8" (200mm),
- 10" (250mm), 12" (300mm)

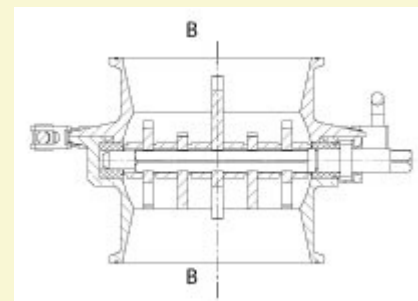

LOOK TO KEY INTERNATIONAL FOR:

PROCESSING EQUIPMENT: Capsule Checkweighers - Capsule Fillers - Capsule Polishers - High Shear Mixers & Granulators - Homogenizers - Metal Detectors - Rotary Tablet Presses - Tablet & Capsule Inspection - Tablet Coaters - Tablet Dedusters - Tablet Friability Testers - Tablet Hardness Testers - CORA Butterfly Valves

PACKAGING EQUIPMENT: Blister Packaging - Bottle Cappers - Bottle Fillers - Bottle Inserters - Bottle Unscramblers - Cartoners - Form/Fill/Seal Pouch Fillers - Single Dose Pre-formed Plastic Shells - Stick Pack Packaging - Suppository Systems - Tablet & Capsule Counters - Tube Fillers - Key-Lon & Key-Lube

9/2015