

CANISTER SILICA GEL INSERTER

Model

CT-CG-120

SPECIFICATION

Container diameter	: 30-100mm
Container height	: 40-200mm
Canister drum diameter	: Up to 20mm
Power	: 0.91 kWh
Air consumption	: 2.3 liters/minute
Output	: 120 containers/minute
Multi insertion	: Up to 5 drums/bottle
Dimension	: 1 200 (L) x 800 (W) x 1 800 (H) mm
Weight	: 250 kg



Canister inserted
verification



Fully interlocked guarding

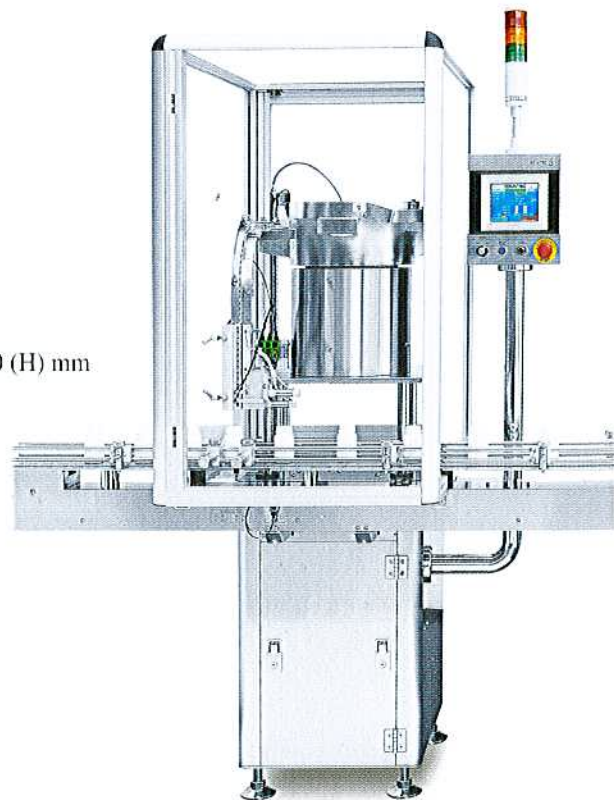

SACHET SILICA GEL INSERTER

Model

CT-SG-120

Designed to use silica gel sachets in roll form.
Sachets fed to cutting station by side gripper belts.
Cutting by reciprocating knife action. Sachet inserted into bottle with plunger action.
Sensors detect end of roll, sachet thickness / eye-mark detect, sachet insertion, stepper motor drive starting point and bottle feed condition.



SPECIFICATION

Container diameter	: 30-100mm
Container height	: 40-200mm
Sachet size	: Up to 60 (L) x 35 (W) mm
Power	: 0.57 kWh
Air consumption	: 1 liters/minute
Output	: 120 containers/minute
Multi insertion	: Up to 5 sachets/bottle
Dimension	: 1 500 (L) x 700 (W) x 1 800 (H) mm
Weight	: 150 kg

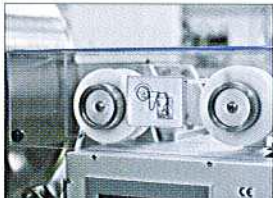

Silica gel feed in roll form

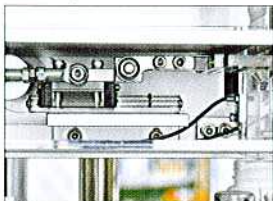

Precise sachet thickness optical sensor control

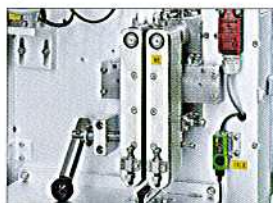

Automatic position alignment side gripping belts

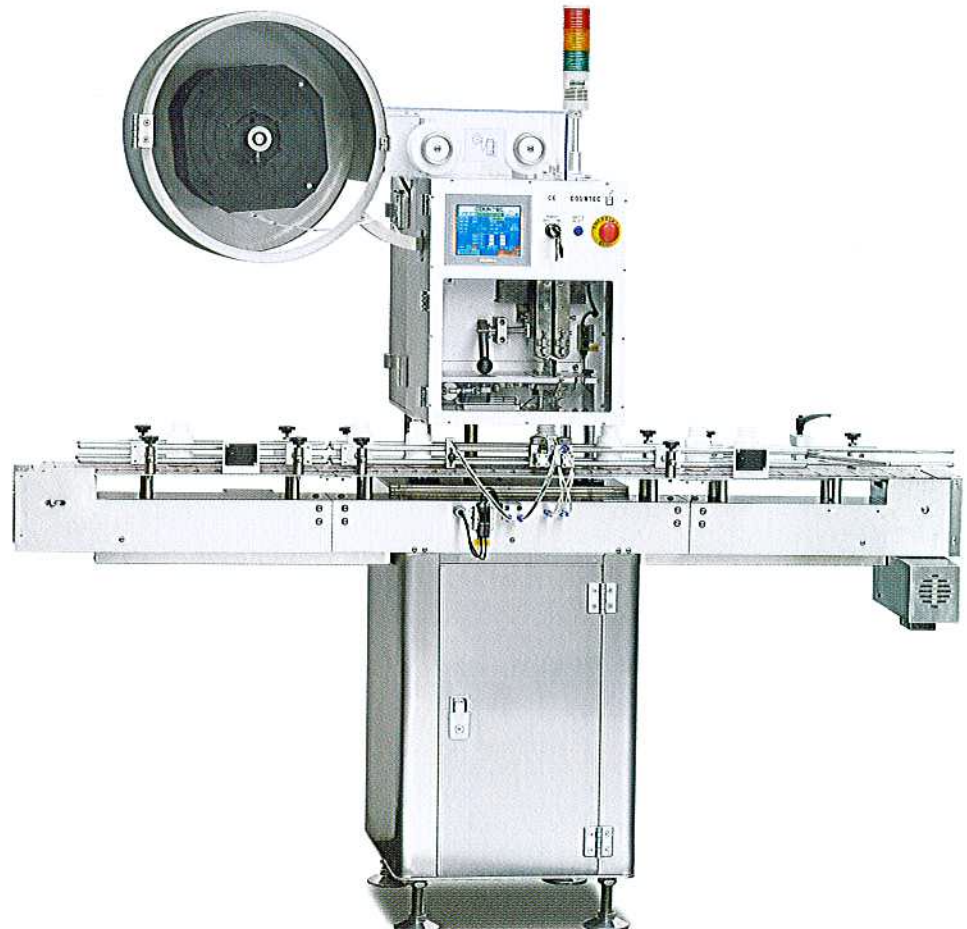



USA DISTRIBUTOR:

Key International, Inc.
4 Corporate Drive, Cranbury, NJ 08512
P: 609-619-3685 F: 609-619-3686
Email: sales@keyinternational.com
Web: www.keyinternational.com

COUNTEC



COUNTEC COMPANY LIMITED

281-31, Dodang-dong, Wonmi-gu
Bucheon, Gyeonggi-do, S. KOREA, 421-808
Tel: 82-32-674-9323 Fax: 82-32-674-9322

For information and sales inquiries

Tel: 82-32-661-3544 Fax: 82-32-661-3547
E-mail: sales@excoss.com

www.countec.com