



# ***Vision Inspection for Tablet & Capsule***

Next Generation  
**PLANET 6G** series

# PLANET 6G

## Tablet and Capsule Vision Inspection

Tablet and Capsule Capability  
Free Shape Tablet Application  
Time Saving New Product Setup  
Rapid Changeover  
cGMP Design



### Enclony Produces

Tablet and capsule inspection machines,  
Empty hard capsule inspection machines and  
Tablet UV Laser printing with inspection machines.

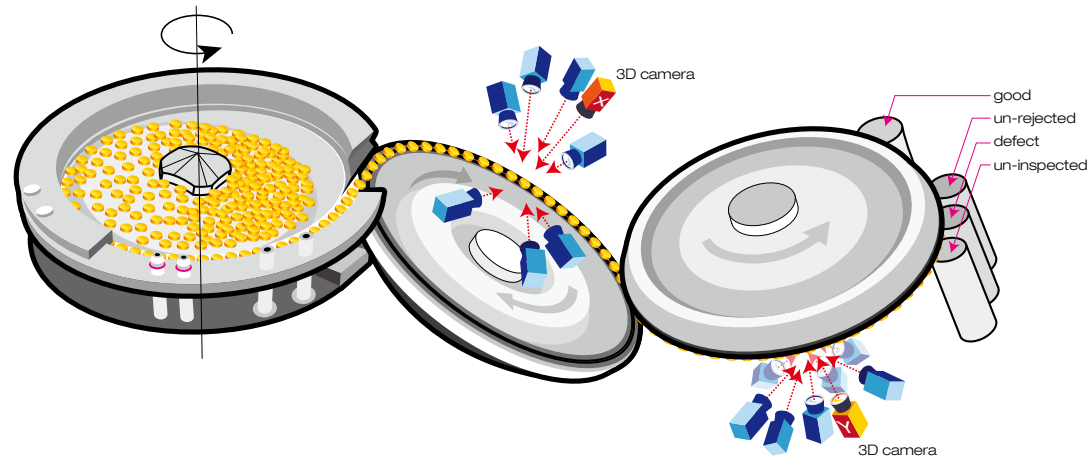
Enclony is committed to continuous research and development of equipment that contributes to world-class product at pharmaceutical manufacturing facilities.

### PLANET 6G series

-  **PLANET 6G/T** for **T**ablet
-  **PLANET 6G/C** for **C**apsule
-  **PLANET 6G/TC** for **T**ablet and **C**apsule

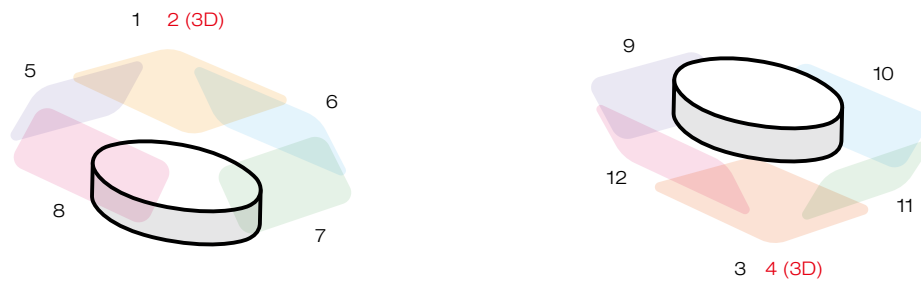


A clean cGMP design is the key concept for PLANET 6G



## Tablet Inspection

Each tablet is inspected by ten interdependent 2D cameras capturing the complete surface area. Two additional 3D cameras capture the surface image of both the top and bottom of each tablet.

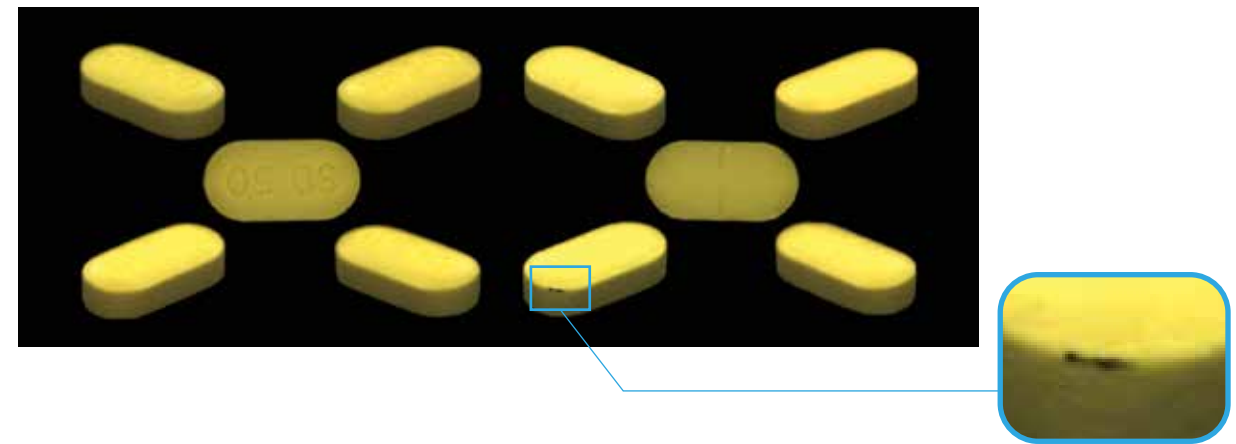


## PLANET 6G has no Blind Spot

Blind spots have been eliminated by capturing each tablet from eight different angles including top and bottom.

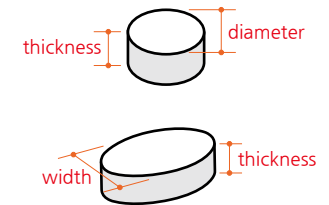


(case of hair on the edge)



## Applicable Tablet Flexibility

- Round Tablet** : diameter allowance **min. 3.5mm - max. 14mm**
- Oblong/Oval Tablet** : width allowance **min. 3.5mm - max. 14mm**, length allowance **min. 8mm - max. 22mm**
- Polygon Shaped Tablets** : triangle, square, diamond, pentagon, hexagon, octagon shapes and so on
- Free Shapes** : heart shape, kidney shape, bean shape, water drop shape, half round shape, almond shape and so on



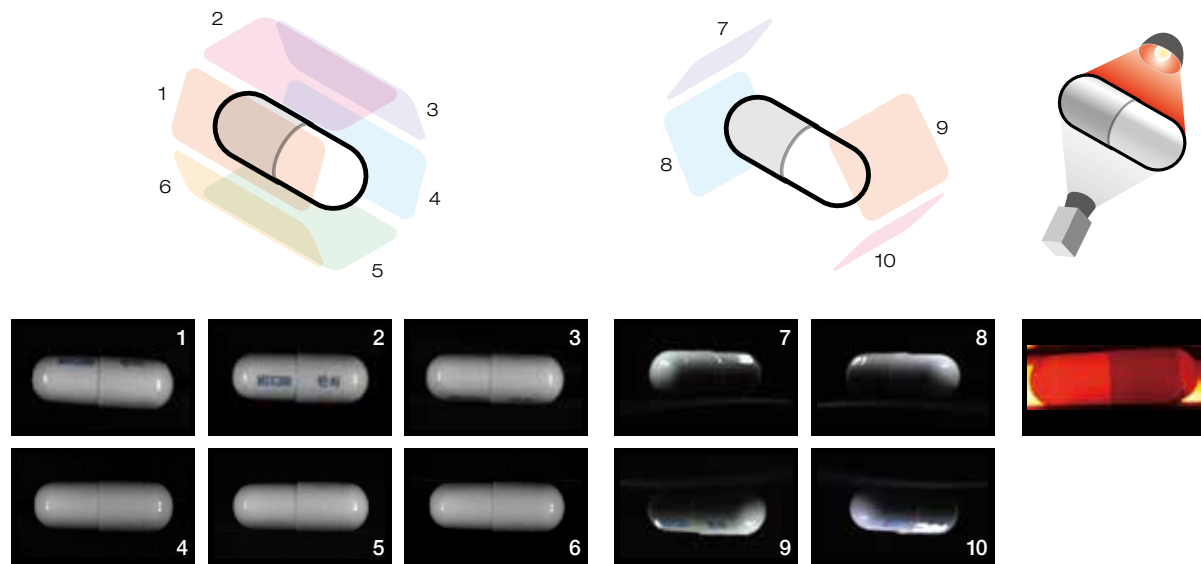
**Allowance of Tablet Difference Dimension (TDD = diameter/width - thickness)  $\geq 0.7\text{mm}$**





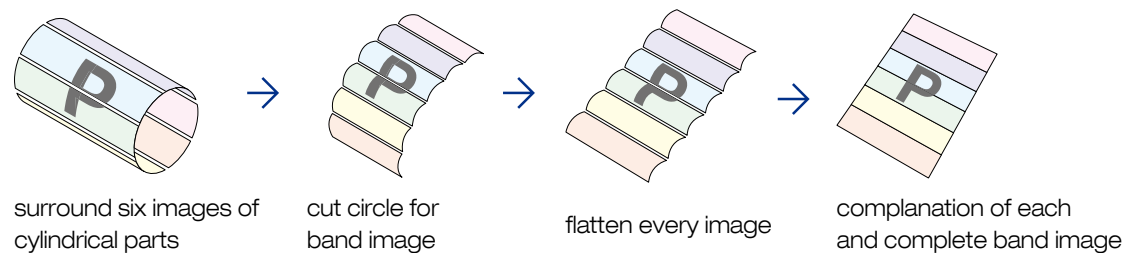
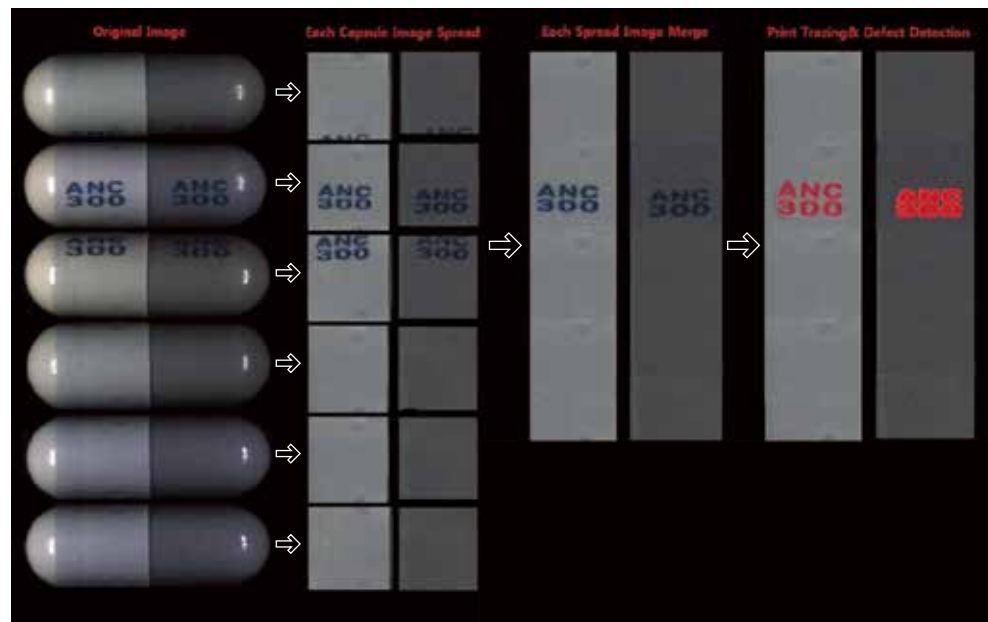
# Capsule Inspection

Each capsule is inspected by ten interdependent 2D cameras capturing the complete surface area. An additional infrared camera identifies empty capsules and checks for filled volume.



## Cylindrical Part

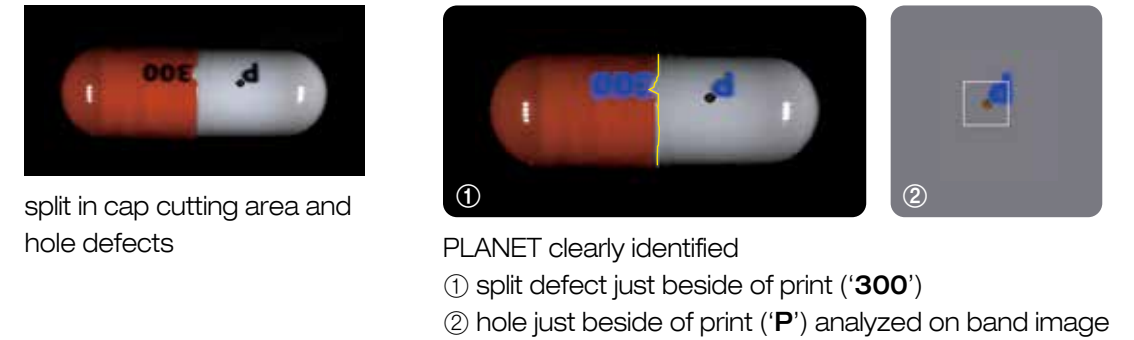
6 images of cylindrical parts are combined and made as a banded image through several steps of image reformation algorithm which is essentially required for detail image analysis.



## Powerful Capsule Inspection by PLANET

### Example 1, Letter Tracing

Print image does not effect to identify defects on capsule.



### Example 2, Joint Line Tracing

PLANET traces joint line on single color of capsule.



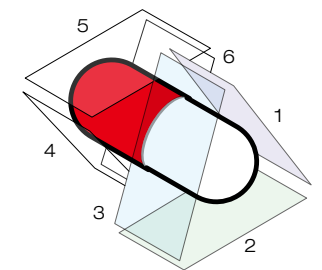
### Example 3, Widely Different Brightness of Cap and Body

PLANET has a special algorithm to divide cap and body to get an optimized image as per specific color on each part. It works well in identifying capsules with widely differing brightness of cap and body.

image for body, lighting sets for bright color (white)

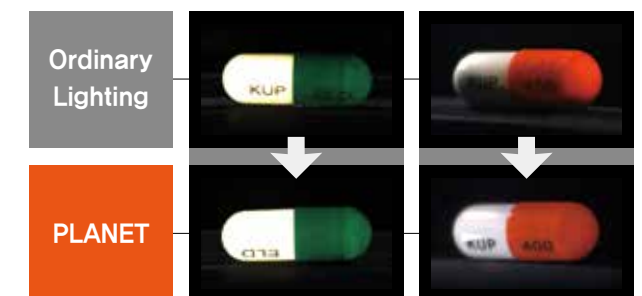


image for cap, lighting sets for dark color (dark red)



## New Lighting System

New lighting system makes almost equal brightness to everywhere of capsule which minimizing of shadow.



### 4 Sides Wing Door Open

Allows full access to the inspection process path.

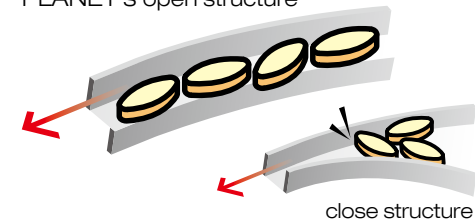
### Smart HMI

Controlled through a very intuitive Smart HMI. This interface controls mechanical setting, inspection fine tuning, and all compliance reports.

### Jam Free Sorting

PLANET uses an open feed structure to prevent jamming of tablets.

PLANET's open structure



### Dust Protected Enclosed Cameras

All cameras and sensors are placed behind glass windows. A protective air curtain reduces dust accumulation.



### Humidity and Temperature sensor

Continuous monitoring of the inspection environment allows the Planet to notify the operator of any conditions that are outside the set range.

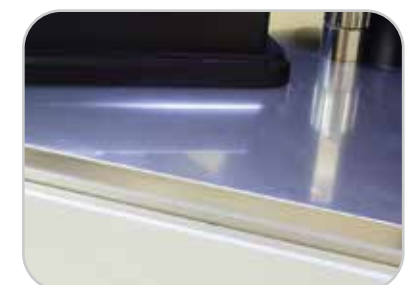
### Discharge

Each tablet is classified as  
1) un-inspected 2) defect  
3) un-rejected and 4) good.



### Threshold free edge

Neat outline design for easy cleaning

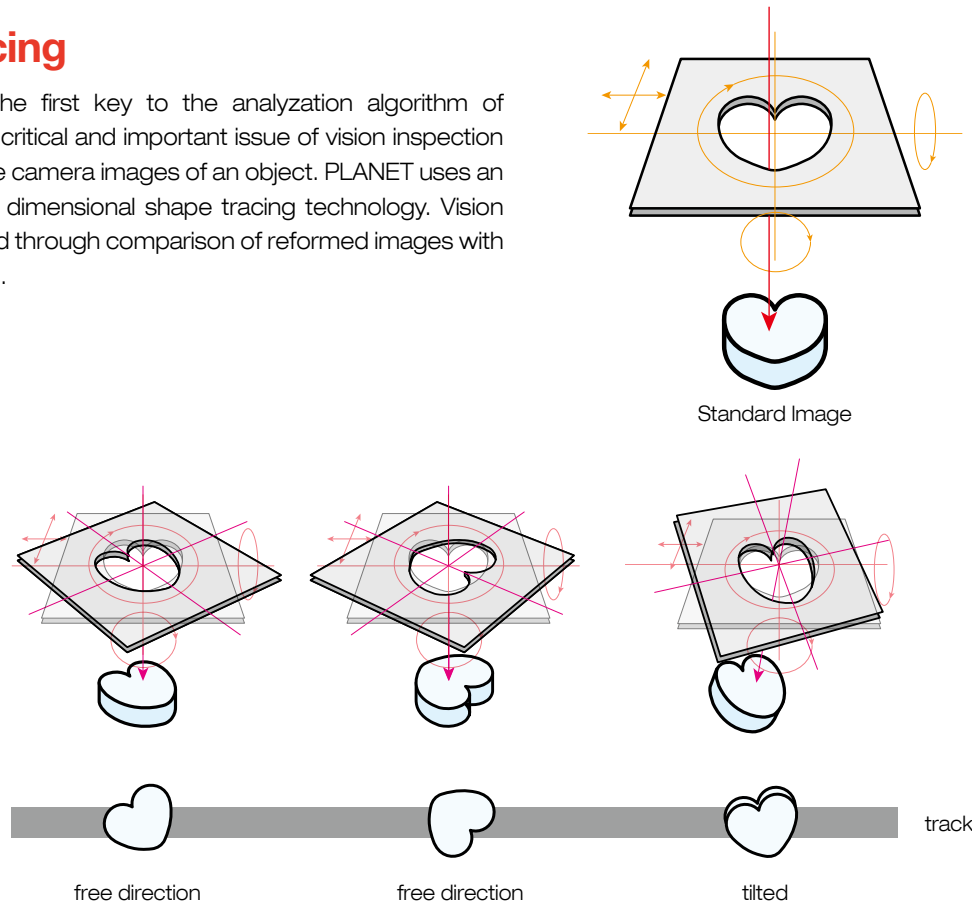




# Analyzing Algorithm

## Shape Tracing

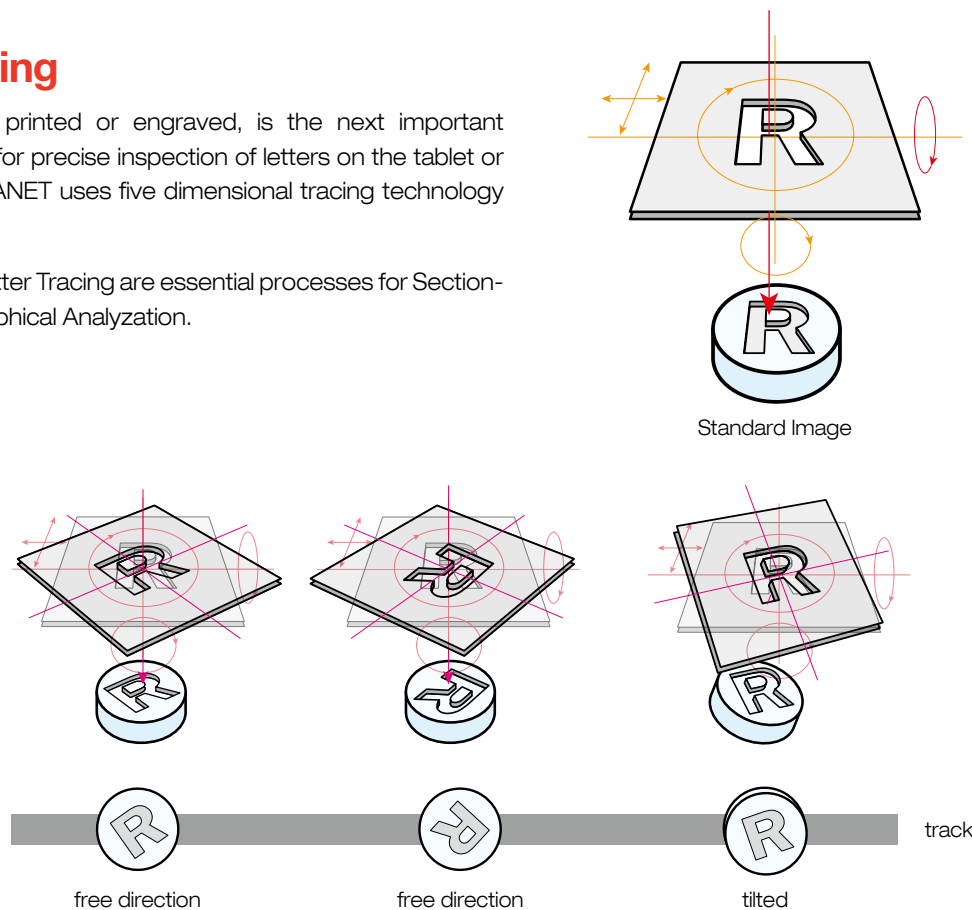
Shape tracing is the first key to the analysis algorithm of PLANET. The most critical and important issue of vision inspection is how to reform the camera images of an object. PLANET uses an algorithm, with five dimensional shape tracing technology. Vision analysis is fulfilled through comparison of reformed images with the standard image.



## Letter Tracing

Tracing of letters, printed or engraved, is the next important technological step for precise inspection of letters on the tablet or capsule. Again, PLANET uses five dimensional tracing technology for letter tracing.

Both Shape and Letter Tracing are essential processes for Sectionization and Geographical Analyzation.



## Sectionization

One single image is sectionized as shown below.

		letter area	edge of letters	general area	outline area
Round					
Oblong					
Free Shape					

## Geographical Analyzation

Every reformed object image by shape and letter tracing is compared with a standard one, pixel by pixel. This algorithm distinguishes the areas where the letter should be and should not be.

## Job Change-Over

PLANET is designed for compact Job change-over in less than one hour. Dismantling (5 min.), cleaning and reassembly (5min.) are done without tools



## Change Parts

The Planet is only mechanically dependent on the width/diameter of the product. With each set of tools covering 1mm of width/diameter, most products can be inspected with 4 to 8 sets of change parts.



one set of size parts

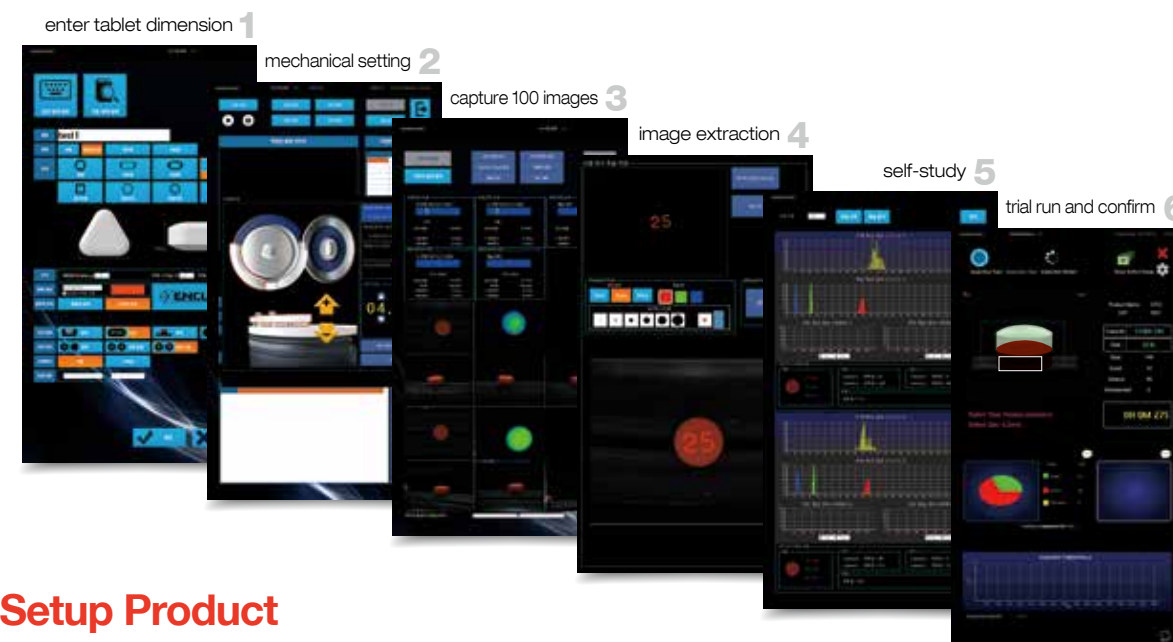
## Auto-Setting of Mechanical Gaps

Product dimensions are programmed through the Smart HMI. All these parameters are saved in each product recipe for easy recall later.

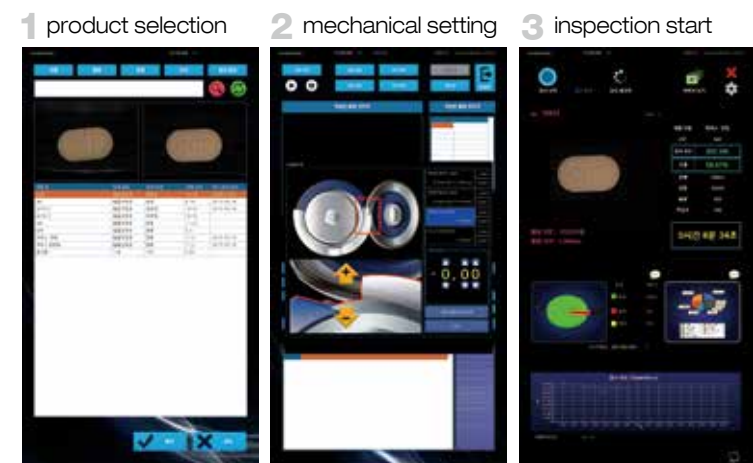


## New Product Setting in 30 Minutes

No factory support is required. The intuitive Smart HMI guides the operator through the process of programming a new product. These 6 steps can be completed within 30-35 minutes.



## Setup Product



Once a product recipe has been created, it's a short 3 step process to start an inspection.

## 128 Multi-Core DSP Board

PLANET's Image Processing Board that is integrated in high density with DSP (Digital Signal Processor) can calculate complex image processing algorithm in real time. With specialized OS developed by Enclony, it makes maximum inspection capability without error or time delay. Image Processing composed of total 128-Core is, in effect, equivalent to the capability of 30 sets of PCs loaded with latest CPU (on Intel i5 basis).



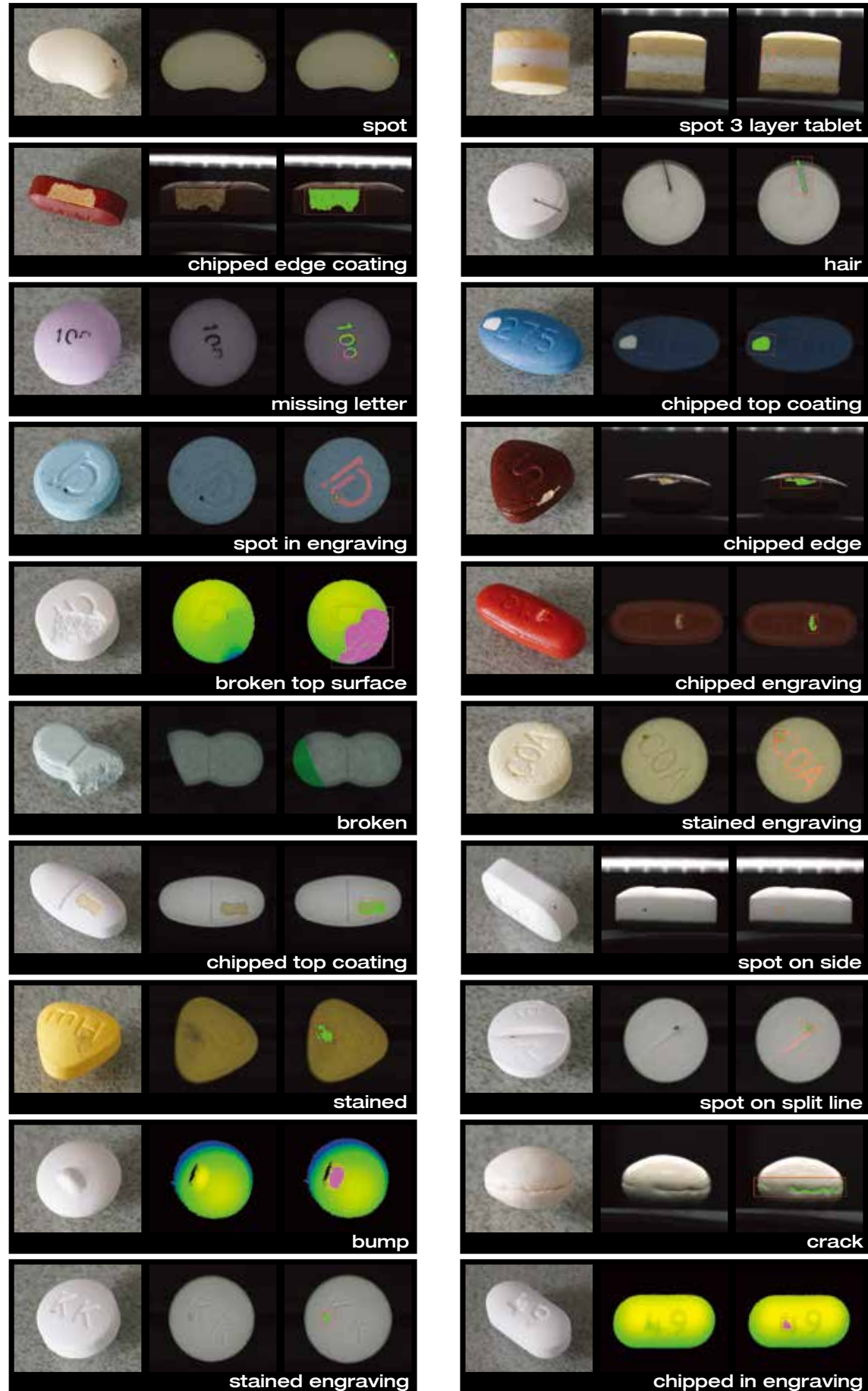
## Compliance with regulations

FDA 21 CFR Part 11, CE, EU GMP, GAMP, UL and so on as option



## Tablet

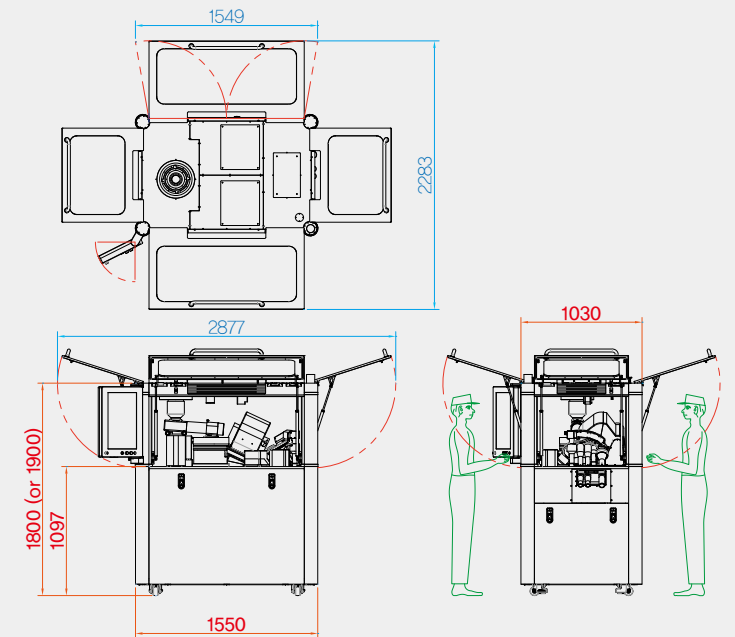
human eye camera image analyzed



## Capsule



### Ergonomic Layout



### Effective Output

**Round tablet**  
 dia. 5mm : up to 350,000 tab./hr  
 dia. 7mm : up to 240,000 tab./hr  
 dia. 9mm : up to 200,000 tab./hr  
 dia. 10mm : up to 180,000 tab./hr  
 dia. 12mm : up to 150,000 tab./hr

**Oblong and Oval tablet**  
 length 10mm : up to 200,000 tab./hr  
 length 14mm : up to 160,000 tab./hr  
 length 17mm : up to 130,000 tab./hr  
 length 21mm : up to 100,000 tab./hr

**Capsule**  
 no. 4 : up to 150,000 cap./hr  
 no. 3 : up to 140,000 cap./hr  
 no. 2 : up to 130,000 cap./hr  
 no. 1 : up to 120,000 cap./hr  
 no. 0 : up to 110,000 cap./hr  
 no. 00 : up to 100,000 cap./hr

Free shaped tablets are restricted as per above dimension. Custom size may require discussion for custom tooling. Actual output is subject to product specific characteristics



## PLANET 6G series



### ENCLONY.COSA

**Marketing and Sales : Cosa Partners Corporation**   [www.cosa.kr](http://www.cosa.kr)

#305, Kolon Idea-Polis, Sohyang-ro 11, Wonmi-gu, Bucheon-si, Gyunggi-do, Korea 14544

E-mail : [sales@cosa.kr](mailto:sales@cosa.kr)   Tel.: +82 32 323 8378   Fax.: +82 32 323 8379

**Manufacturing : Enclony Co., Ltd.**   [www.enclony.com](http://www.enclony.com)

#910, Ace Twin Tower 1, Digital-ro 285, Guro-gu, Seoul, Korea 08381

E-mail : [enclony@enclony.com](mailto:enclony@enclony.com)   Tel.: +82 2 855 0095   Fax.:+82 70 8650 4810

**Enclony-Europe in Frankfrut, Germany**

E-mail : [sales@cosa.kr](mailto:sales@cosa.kr)

Contents on this catalogue are to assist understanding of the equipment only and are subject to technical modifications without prior notice. The final specifications is as per our quotation offered to you exclusively.