

SPECIFICATIONS:

UTILITIES:

ELECTRIC-----110V/1PH/60HZ  
 AIR-----1 TO 2 CFM  
 VACUUM-----20 TO 30 CFM

CONSTRUCTION:

INFEED CHUTE-----AISI 304 SST, #7 POLISH  
 INFEED TUBE-----AISI 304 SST, #7 POLISH  
 SCREEN (60% OPEN)- AISI 304 SST  
 POWDER FUNNEL-----AISI 304 SST, #7 POLISH  
 COVER-----LEXAN (POLYCARBONATE)  
 SCREEN HOUSING-----AISI 304 SST, #7 POLISH  
 DISCHARGE CHUTE-----AISI 304 SST, #7 POLISH

MISC.

WEIGHT, NET = 36 LBS.  
 WEIGHT, SHIP = 50 LBS.  
 DECIBEL LEVEL = 52 @ 3 FT.

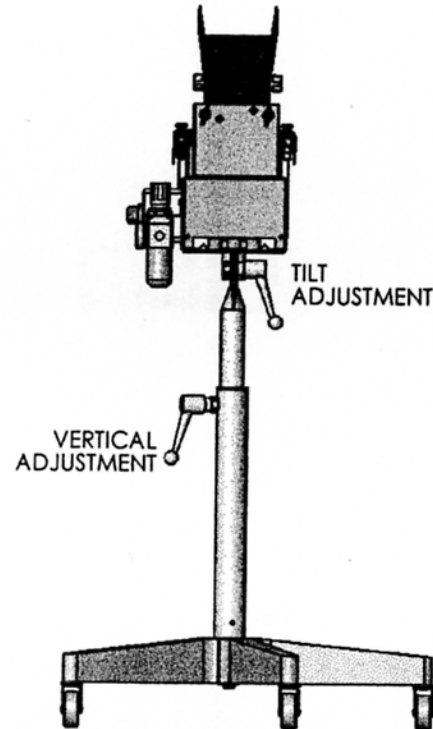
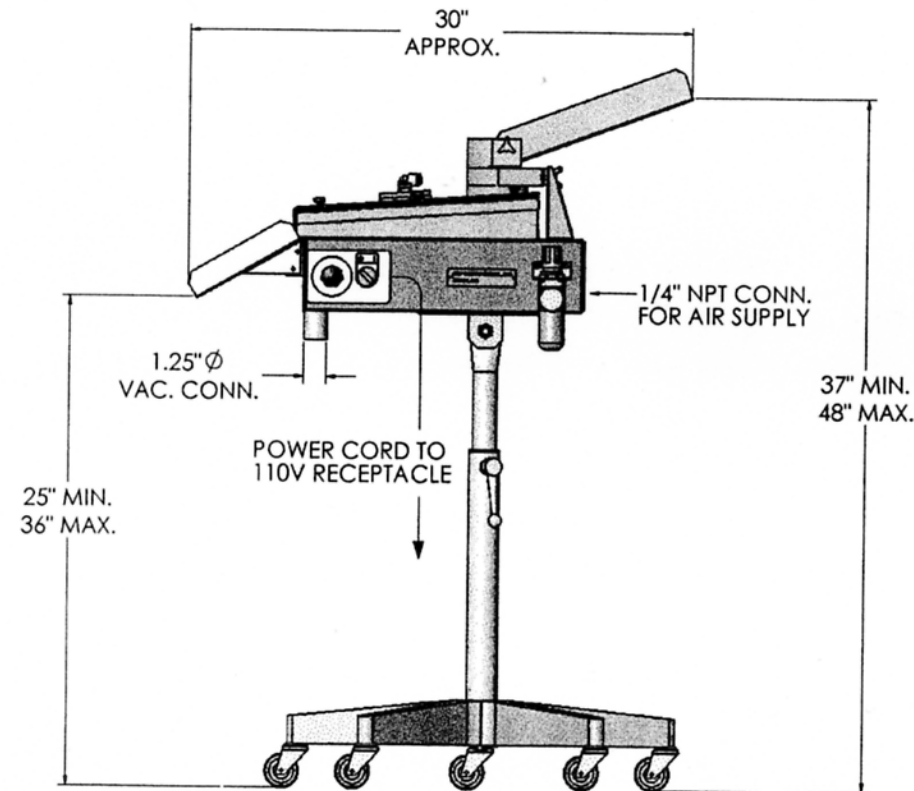

KEY INTERNATIONAL, INC.  
 480 ROUTE 9  
 ENGLISHTOWN, NJ 07726

TITLE: TABLET DEDUSTER  
 MODEL TD-101WD

MAR. 2004

DWG. NO.

2-061-0000W

BY: JPC

REV