

KEY AIR-VEYOR MODEL AV200

*TRANSPORT SYSTEM FOR TABLETS, CAPSULES, & PARTS
FROM ONE STATION TO THE NEXT IN THE PROCESSING AREA*

The Key **AIR-VEYOR** is designed to convey products to an accommodating discharge height and transport them between any two stations in the processing area. Since the **AIR-VEYOR** requires only plant compressed air, it is simply designed with no motors or moving parts. Air flow is also adjustable to ensure optimum flow thru efficiency of most any size, shape and weight product.

A BETTER CHOICE VERSUS OTHER METHODS

The **AIR-VEYOR** offers significant advantages as compared to cleat belt conveyors or vacuum transfer systems. These include a simpler, more reliable design; no electrical requirements; greater positioning flexibility and a much lower price to buy and use. The Key **AIR-VEYOR** is the new best answer for moving product from point A to point B... just about anywhere, from manufacturing to final packaging.

FEATURES

- Efficient, reliable, low cost
- GMP design
- 100% washdown
- Simple, lightweight, no moving parts
- Easy to set up and clean
- No electricity requirement
- 3" x 6" rectangular inlet funnel
- Adjustable feed height
- Portable stand with non-skid pads
- FDA approved smooth bore hose
- "T" discharge fitting for drum or tote cover
- Variable speed control
- No routine maintenance
- Made in U.S.A.

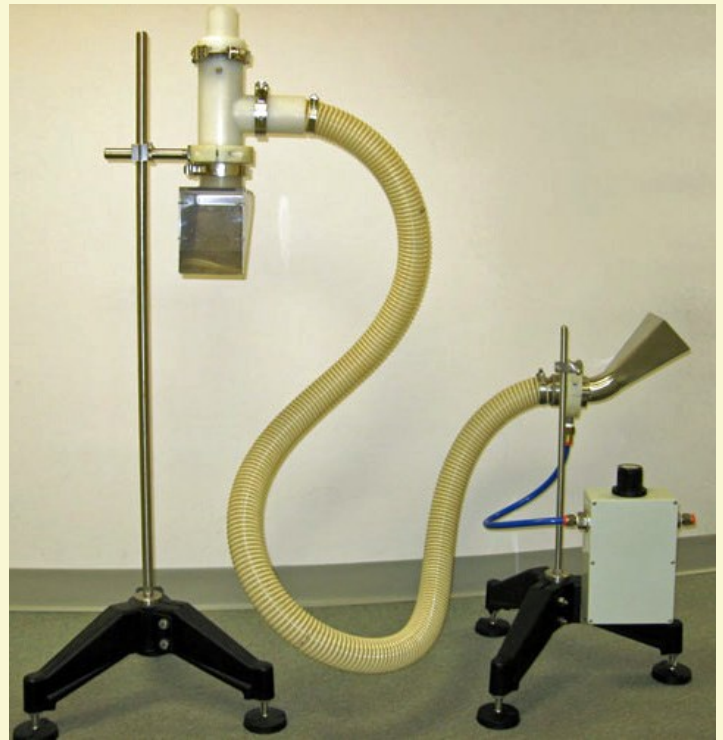

KEY AIR-VEYOR MODEL AV200

**TRANSPORT SYSTEM FOR TABLETS, CAPSULES, & PARTS
FROM ONE STATION TO THE NEXT IN THE PROCESSING AREA**

TYPICAL TABLET/CAPSULE APPLICATIONS

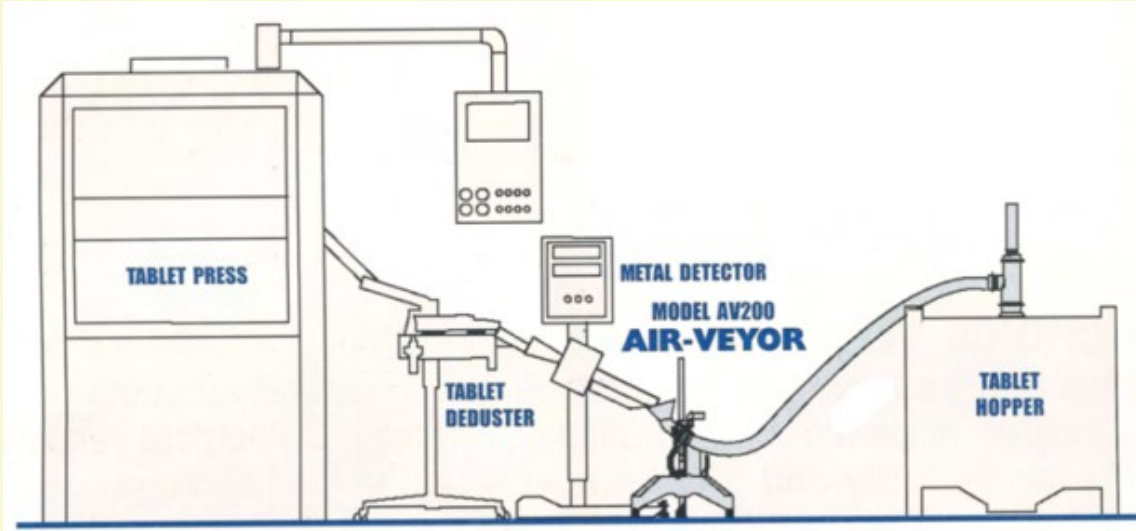

- Metal detector hopper (shown)
- Tablet press to deduster
- Deduster to metal detector
- Deduster to inspection station
- Metal detector to check-weigher
- Check-weigher to bulk container
- Capsule filler to polisher
- Capsule polisher to inspection station

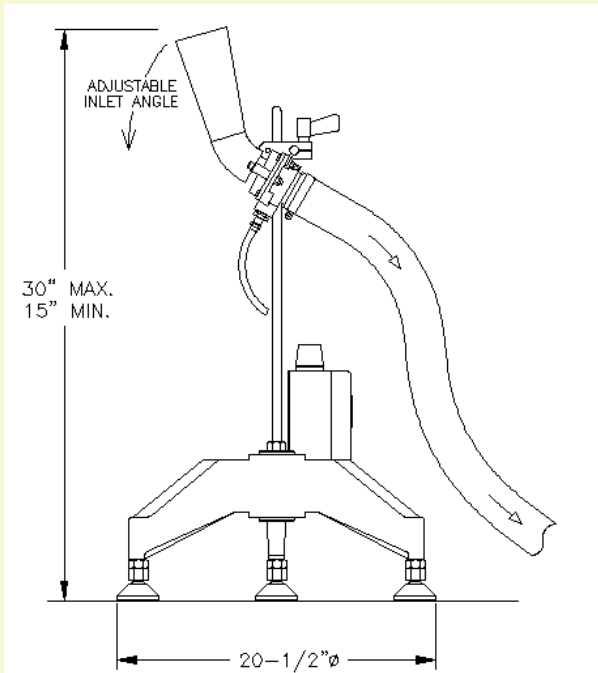

**CONVEYS PRODUCT UP TO
10'/3000 PER/MIN**

POWER

Compressed air:
50psi / consumption 6.5cfm

OPTIONS

- 15 micron filter bag for product exhaust
- Product receiver with independent support stand
- Custom units for special application

LOOK TO KEY INTERNATIONAL FOR:

PROCESSING EQUIPMENT: Capsule Checkweighers - Capsule Fillers - Capsule Polishers - High Shear Mixers & Granulators - Homogenizers - Metal Detectors - Rotary Tablet Presses - Tablet & Capsule Inspection - Tablet Coaters - Tablet Dedusters - Tablet Friability Testers - Tablet Hardness Testers - CORA Butterfly Valves

PACKAGING EQUIPMENT: Blister Packaging - Bottle Cappers - Bottle Fillers - Bottle Inserters - Bottle Unscramblers - Cartoners - Form/Fill/Seal Pouch Fillers - Single Dose Pre-formed Plastic Shells - Stick Pack Packaging - Suppository Systems - Tablet & Capsule Counters - Tube Fillers - Key-Lon & Key-Lube

08/2015

Key International, Inc.
4 Corporate Drive
Cranbury, New Jersey 08512

Phone: 609-619-3685
Fax: 609-619-3686
Email: sales@keyinternational.com
Web: www.keyinternational.com