



Layout



Description		Model		
		4S/4S	8S	9S
Numbers of Stations		4/4	8	9
Pitch Circle Diameter (Ø mm)		130		
Max. Output	Single	9,600	19,200	24,300
Revolution of Disk (rpm)	Single	40	45	40
Max. Tablet Diameter	Round (Ø mm)	25	25	16
	Oblong (mm)	25/19	25	19
Max. Tablet Thickness (mm)		8.5		
Filling Depth (mm)		18	22	18
Upper Punch Insert (mm)		1- 4		
Max. Pre Pressure (kg-f)		-		
Max. Main Pressure (kg-f)		6,000		
Die Type		D/B	D	B
Punch Type		EU-D/B	EU-D, TSM-D	EU-B, TSM-B
Machine Height (mm)	Excluding Hopper	1,570		
	Including Hopper	1,780		
Machine Floor Space (mm)		600 x 1,200		
Weight (kg)		550		
Power Supply		220 / 380 / 400 / 415V, 50 / 60 Hz, 3Phase		

- Plug and play
- AWC
- 21 CFR Part 11
- Mechanical feeder (bar and round type)
- R&D and clinical test

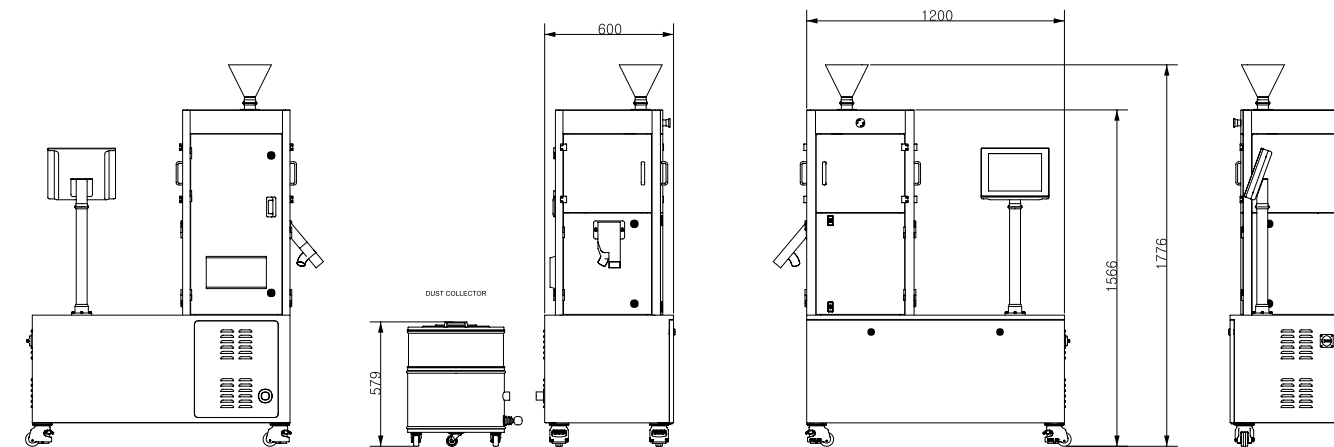
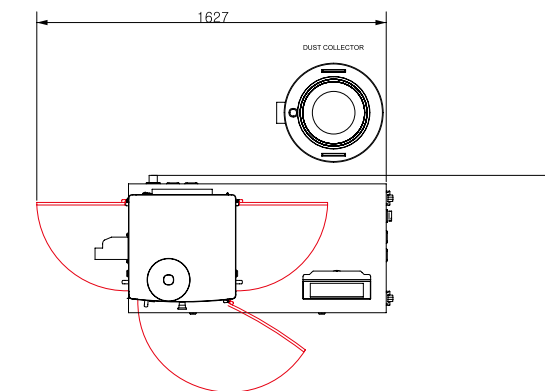

VANTIX Series

Optimized Technology

VANTIX



63, Annam-ro 402beon-gil, Bupyeong-gu, Incheon, Korea zip.21314
Tel. 032-508-1284 Fax. 032-508-1289

www.sjpm.com

USA Distributor:



*One Company.
One Source.
Since 1968.*

4 Corporate Drive
Cranbury, NJ 08512

P: 609-619-3685
F: 609-619-3686
sales@keyinternational.com
www.keyinternational.com

